

Data, dimensions and types

Contents

boomer one [Page 4](#)  
boomer two [6](#)  
waver [8](#)  
stones [10](#)  
pato [12](#)  
osa [14](#)  
lounger [16](#)  
shorty [18](#)  
tabloo [20](#)  
kirk [22](#)  
seating bubble [24](#)



## boomer one

boomer is sensuous in every respect and rich of contrasts: The organically floating shape, the precise closure and the material that seems to be so hard. Present but reserved at the same time, organic and soft, even fragile, boomer is veritably floating

With boomer one the designer, Elke Berger, and the architect, Norman Herwig, not only developed a piece of seating furniture but also a sculpture that vividly approaches and follows ambient and waving shapes, fitting snugly to them and continuing their motion. For this niche boomer is meeting requirements way beyond any standards whatsoever.

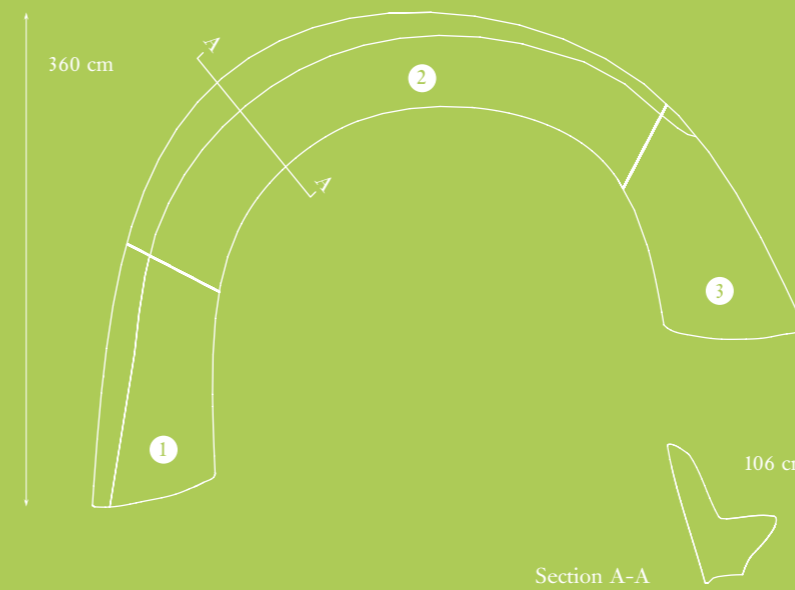
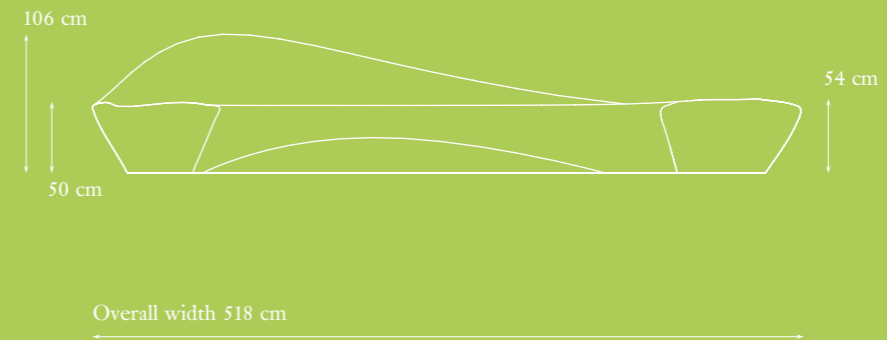
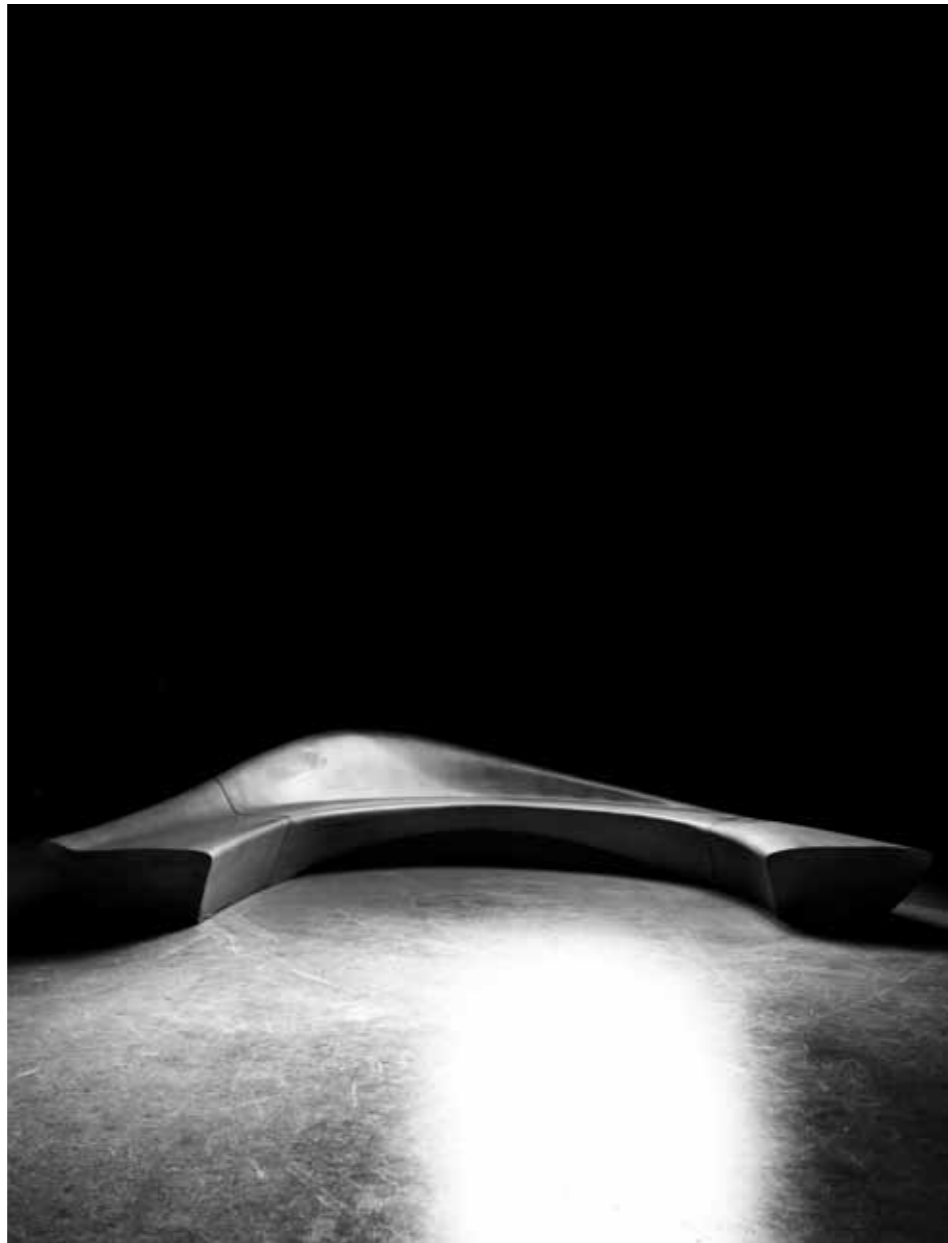

### boomer one

Sculptural glass fibre concrete bench consisting of three modules. Design options with high-class, natural colour pigments that are mixed into the matrix. The glass fibre concrete is not only supplied with a colour but is also imbued.

### Available colours

- Dark-grey
- Anthracite
- Concrete-grey
- Cream-white

### Weight

Total weight: 880 kg  
Module 1: 200 kg  
Module 2: 500 kg  
Module 3: 180 kg



design Elke Berger and Norman Herwig

## boomer two

boomer is sensuous in every respect and rich of contrasts. The organically floating shape, the precise closure and the material that seems to be so hard. Present but reserved at the same time, organic and soft, even fragile, boomer is veritably floating.

With boomer two the designer, Elke Berger, and the architect, Norman Herwig, not only developed a piece of seating furniture but also a sculpture that vividly approaches and follows ambient and waving shapes, fitting snugly to them and continuing their motion. For this niche boomer is meeting requirements way beyond any standards whatsoever.

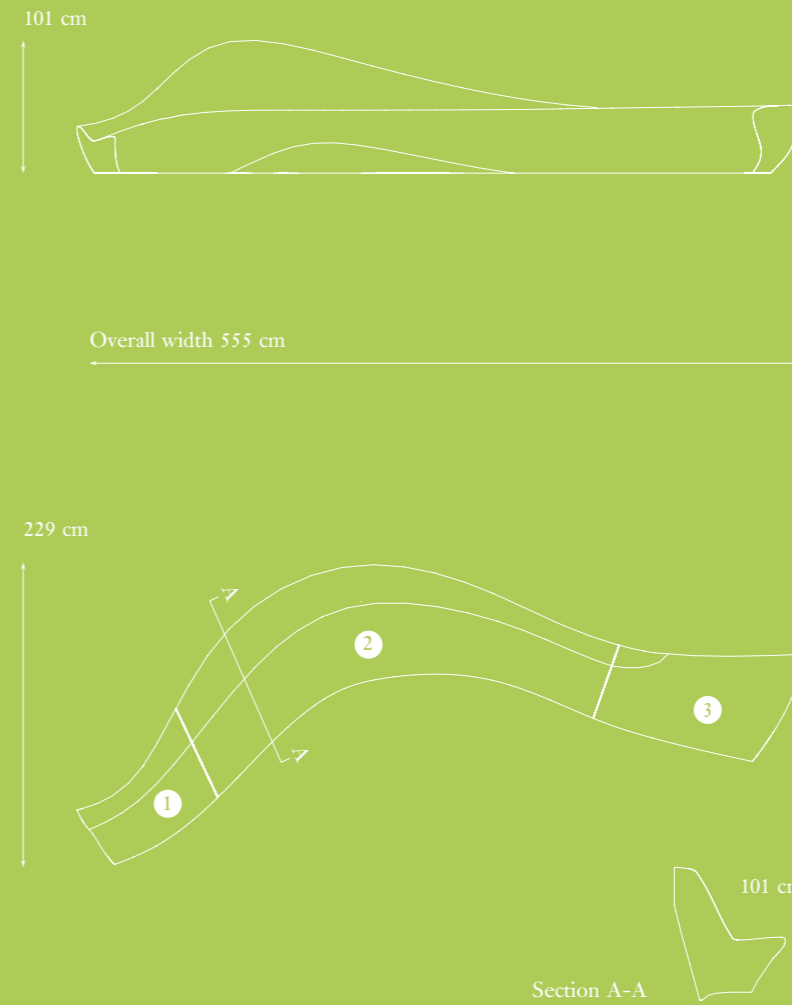

### boomer two

Sculptural glass fibre concrete bench consisting of three modules. Design options with high-class, natural colour pigments that are mixed into the matrix. The glass fibre concrete is not only supplied with a colour but is also imbued.

### Available colours

- Dark-grey
- Anthracite
- Concrete-grey
- Cream-white

### Weight

Total weight: 710 kg  
Module 1: 110 kg  
Module 2: 450 kg  
Module 3: 150 kg



design Elke Berger and Norman Herwig

## waver

Waver broadens the sensory perception of a three-dimensional piece of furniture by an auditory moment. Therefore an approach is not only possible when sitting or lying but now also with the ears.

With “waver” the idea of a “speaking piece of furniture” which originated while working on a draft for the Campus of the regional flower show in Aschersleben in 2010 is taking shape, inspired by the leaf of the *Olearia Arborescens*, an evergreen bush plant from the lowlands of New Zealand’s North Island. The designer, A.W. Faust, developed its characteristic shape from a series of draft elements to a geometrically varying shape that was equipped with an audio system.

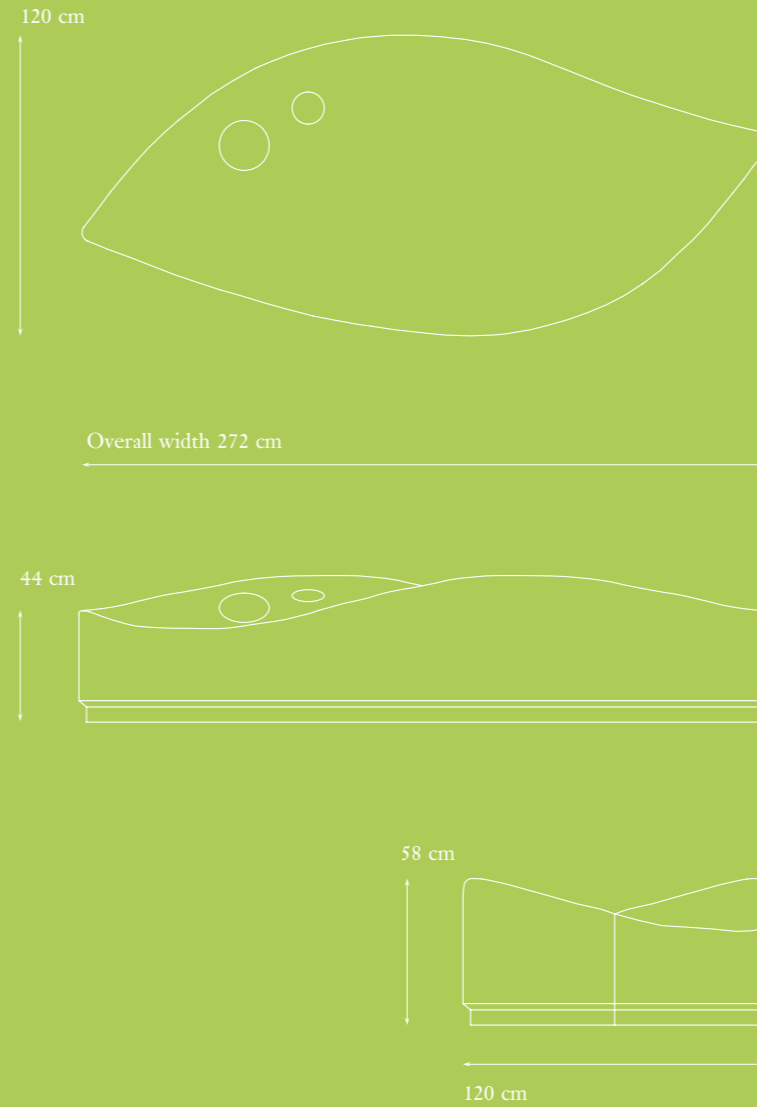

### waver

Sculptural, wave-shaped bench and lounge of glass fibre concrete. Design options with high-class, natural colour pigments that are mixed into the matrix. The glass fibre concrete is not only supplied with a colour but is also imbued. With an audio system as an option. The two openings are generally incorporated into Waver. Covers of rust-proof stainless steel.

### Available colours

- Dark-grey
- Anthracite
- Concrete-grey
- Cream-white

### Weight

Total weight: 300 kg



design A.W. Faust

## stone

A cut pebble in a watery creek bed – stone is taking up the familiar shape and is creating a distressing but nevertheless fascinating dimension. Just as if it were an appealing invitation to take a seat, interconnect and communicate.

Stone is a hand-charming touchstone in XL format, spectacularly dimensioned and yet so lightweight. Its natural look and the rough velvety surface are showing the glass fibre concrete's exceptional visual appearance and haptics to their very best advantage. Stones are introducing new accents indoors and outdoors, for playing, lying or sitting. Or simply just as an eye-candy; on the playground, in the park or in your own garden.



design Eva Rudolph

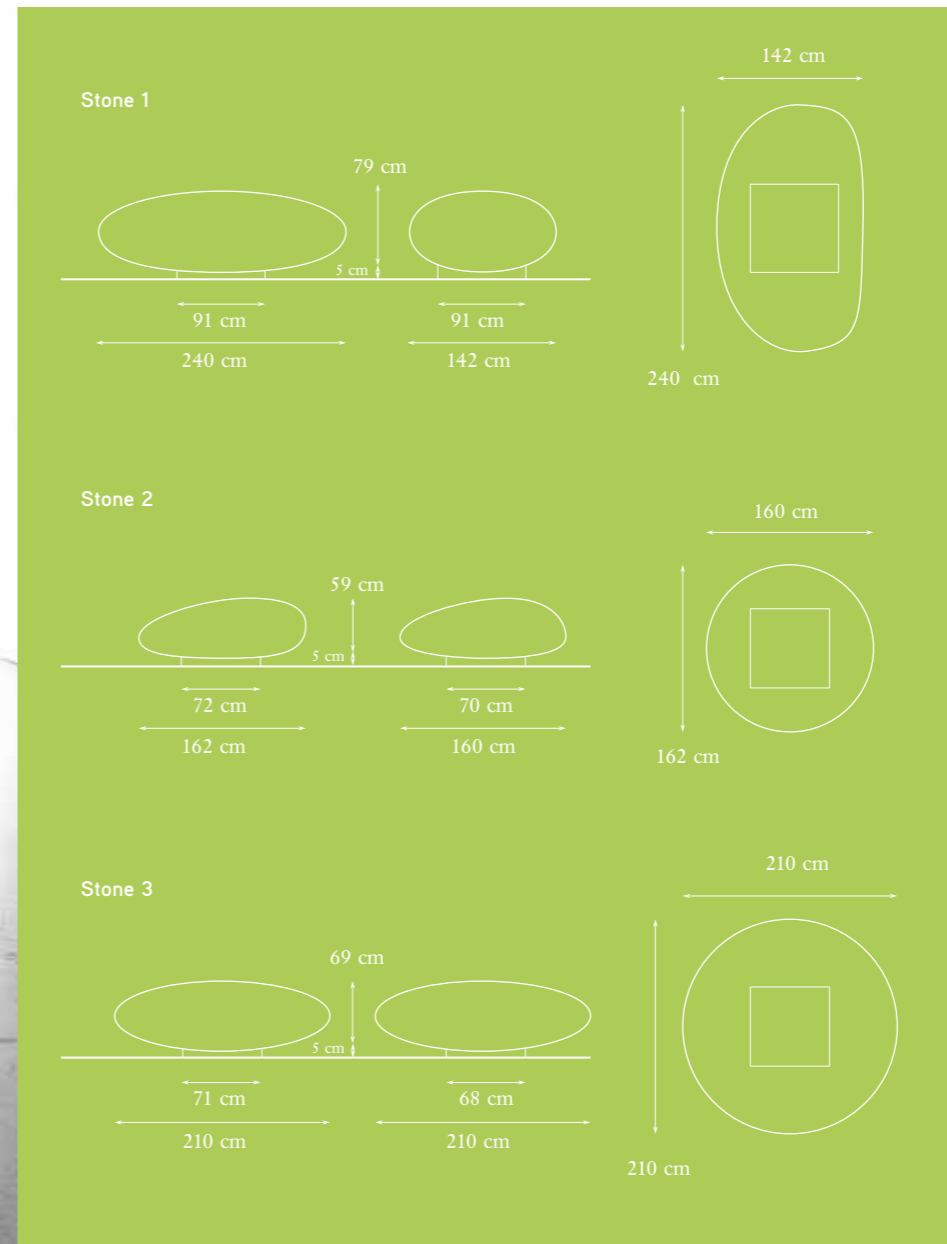

### stones

Stones of glass fibre concrete for playing, seating or lying around. Design options with high-class, natural colour pigments that are mixed into the matrix. The glass fibre concrete is not only supplied with a colour but is also imbued.

### Available colours

- Dark-grey
- Anthracite
- Concrete-grey
- Cream-white

### Weight

Stone 1: 640 kg  
Stone 2: 350 kg  
Stone 3: 500 kg

## pato

Simple but with a certain sophistication that distinguishes the outstanding from the mundane. This is the spirit in which pato had been developed.

Pato, a flower trough in a captivating stylistic shape – simple yet not too dominant. Pato is particularly showing to advantage when in rows and combined with other troughs. It is a very robust element and therefore well prepared to withstand the various environmental and climatic impacts.



### pato

Seven different flower troughs of thin-walled glass fibre concrete. Design options with high-class, natural colour pigments that are mixed into the matrix. The glass fibre concrete is not only supplied with a colour but is also imbued.

Supplied with galvanized metal insert.

### Available colours

- Dark-grey
- Anthracite
- Concrete-grey
- Cream-white

### Weight

- Pato 1: 41 kg
- Pato 2: 50 kg
- Pato 3: 104 kg
- Pato 4: 134 kg
- Pato 5: 258 kg
- Pato 6: 331 kg
- Pato 7: 410 kg



design Eva Rudolph

## osa

Design is great when it makes sense and is beautiful. Osa counts to those things you want to touch because the elements are beautiful. Osa is also multifunctional. This makes sense. Simply good design.

Osa is vandalism-proof and also provides space for the city's brochures and information for tourists. The bench is modular and can be arranged around a tree. Spots under a glass cover in the recess are submerging the tree top into subdued light during the night. Osa is individual and yet less expensive than a standard piece of furniture.

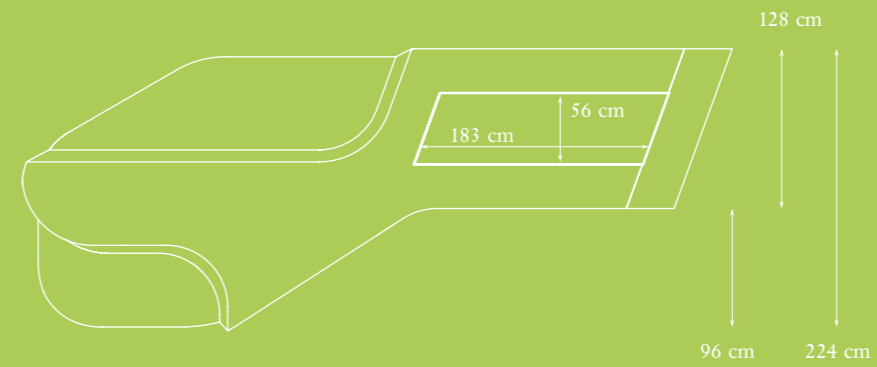

Overall width 570 cm



### osa

Bench consisting of two modules with the option to integrate vertical elements, e.g. trees. Wooden seat. The hollow space may be used for an ambient light. Various colours are available. Made of reinforced concrete C30/37.

### Available stains

- Dark-grey
- Anthracite
- Concrete-grey
- Cream-white

### Weight

7.600 kg



design Frank Prochiner



## lounger

With the concept for the lounger the designer is moving about border areas. Thin as paper with clear and precise lines and yet strong and solid.

Can a lounger made of concrete be comfortable? Yes, it can, if the shape follows man's contours like the lounger's curves do. You quickly forget sitting on such a heavy and massive piece of furniture. For their designer the fascination is in this contradiction – pieces of furniture made of glass fibre concrete are fine, yet rough chaps. They are timeless objects that people still will be fond of after years.

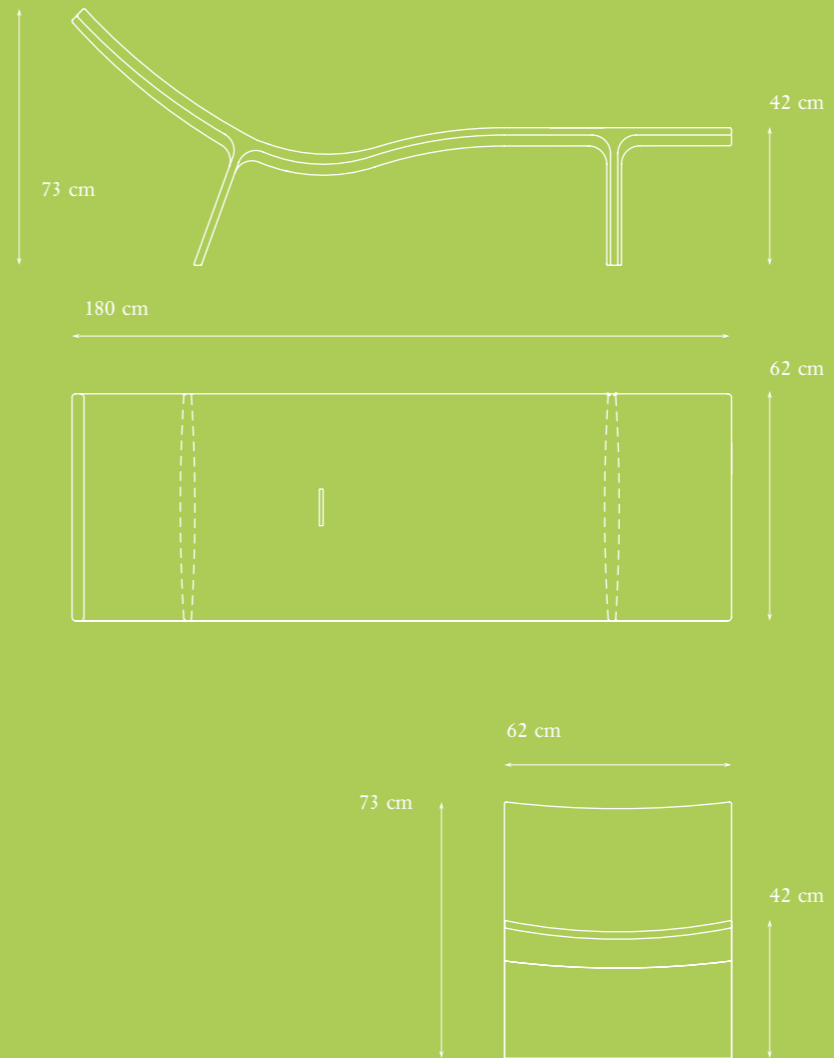

### lounger

Filigree lounger of glass fibre concrete. It can be disassembled into three pieces for transportation. As an option a heating source may be incorporated into the lying surface. It can be particularly well combined with the shorty and the tabloo. Design options with high-class, natural colour pigments that are mixed into the matrix. The glass fibre concrete is not only supplied with a colour but is also imbued.

### Available colours

- Dark-grey
- Anthracite
- Concrete-grey
- Cream-white

### Weight

110 kg



design René Holten

## shorty

With the concept for the shorty the designer is moving about border areas. Thin as paper with clear and precise lines and yet strong and solid.

Shorty shows a clear contour. The flexible steel leg emphasizes its lightness and makes it even floating. Gentle swaying movements make you forget sitting on such a heavy and massive piece of furniture. Pieces of furniture made of glass fibre concrete are fine, yet rough chaps. They are timeless objects that people still will be fond of after years.

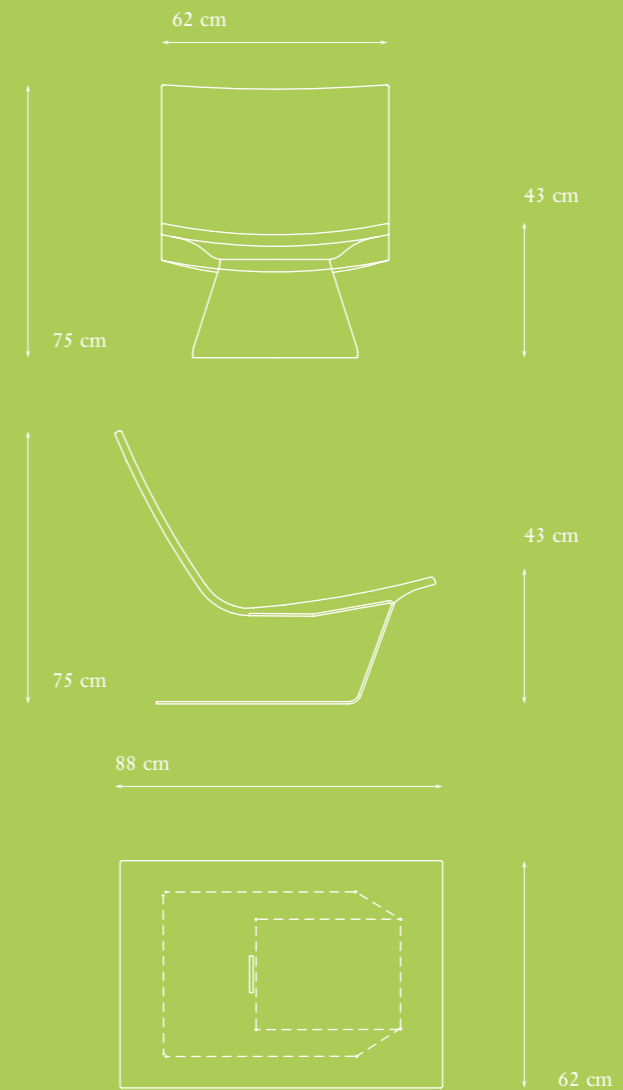

### shorty

Filigree chair of glass fibre concrete with a leg of sheet steel. It can be particularly well combined with the shorty and the tabloo. Design options with high-class, natural colour pigments that are mixed into the matrix. The glass fibre concrete is not only supplied with a colour but is also imbued.

### Available colours

- Dark-grey
- Anthracite
- Concrete-grey
- Cream-white

### Weight

64 kg



design René Holten

## tabloo

The ensemble of lounge, shorty and tabloo has a clear and precise line and yet is strong and solid. With a vividness as light as a feather – cast in concrete.

The side table tabloo is functionally and structurally completing this trio. Made of thin walls it radiates the lightness of a bended sheet of paper, although it has the very same product features as all other pieces of furniture from the Concrete® Urban Design series of glass fibre concrete – timeless objects that people still will be fond of after years.

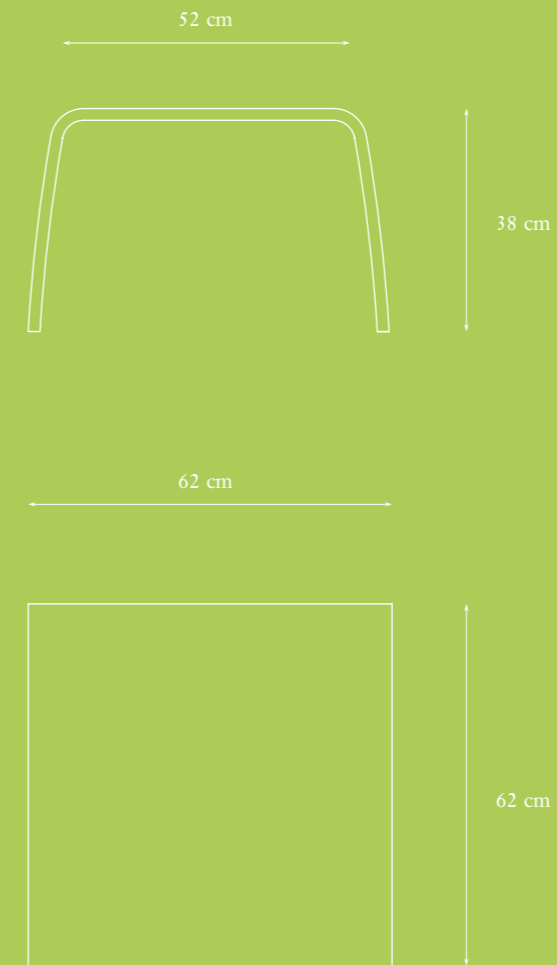

### tabloo

Filigree side table of glass fibre concrete. It can be particularly well combined with the lounge and the shorty. Design options with high-class, natural colour pigments that are mixed into the matrix. The glass fibre concrete is not only supplied with a colour but is also imbued.

### Available colours

- Dark-grey
- Anthracite
- Concrete-grey
- Cream-white

### Weight

34 kg



design René Holten

## kirk

Kirk seems like a flying saucer and its name, of course, brings back memories of the legendary USS Enterprise and its commander.

On the first glance the chair seems to be somewhat substantial but nevertheless appears to be light, like floating on its spider legs of steel. Sitting therein conveys a feeling of privacy, protected by its shape and richness of material, just as if it were an island, a very special place. As an option kirk is also available in a row of chairs.

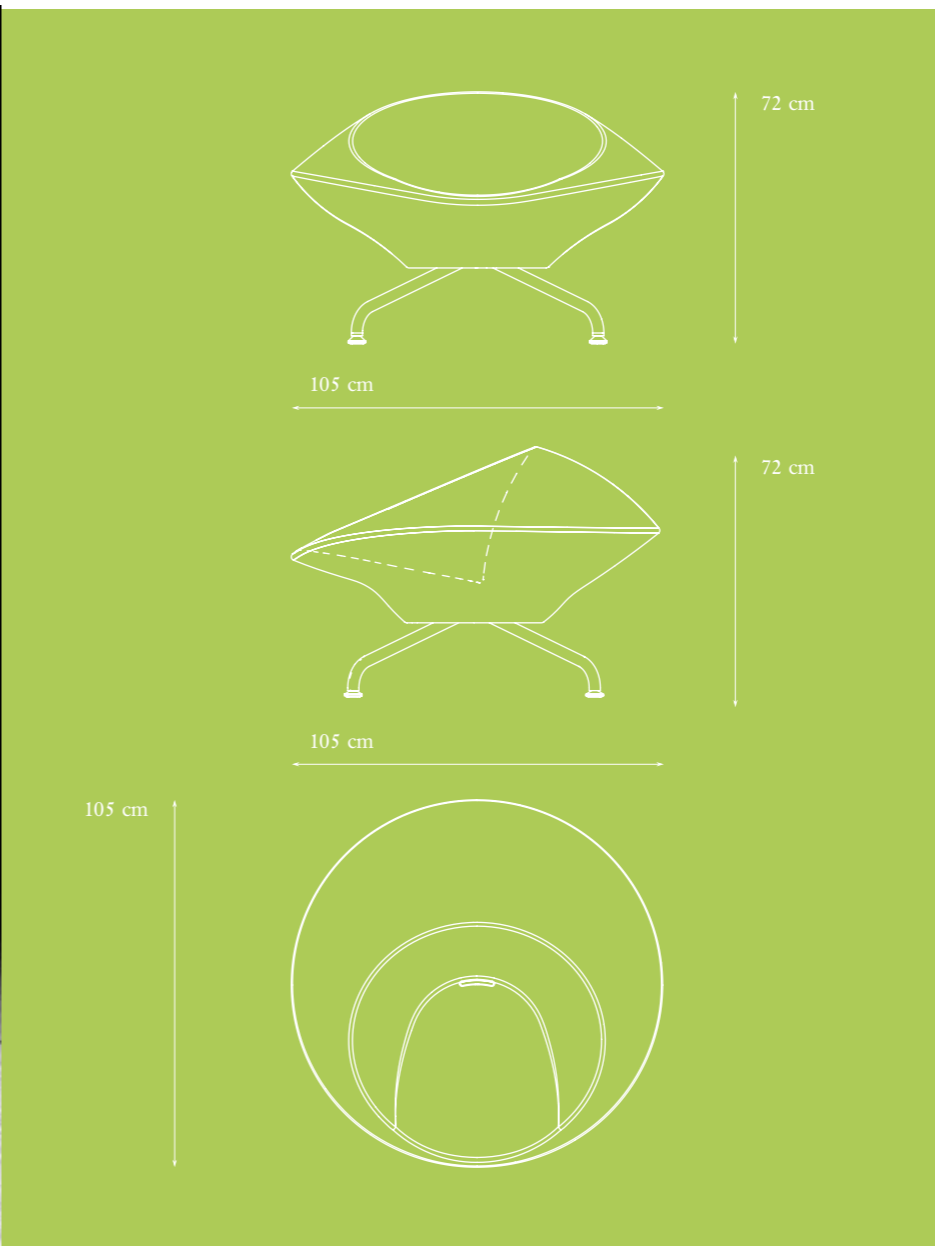

**kirk**  
Filigree chair of glass fibre concrete with legs of sheet steel. Design options with high-class, natural colour pigments that are mixed into the matrix. The glass fibre concrete is not only supplied with a colour but is also imbued.

- Available colours**
- Dark-grey
  - Anthracite
  - Concrete-grey
  - Cream-white

**Weight**  
120 kg



design René Holten

## seating bubble

It was initially designed to furnish playground areas. The seating bubbles by Concrete® Urban Design meanwhile showed, however, that they can be universally used.

Owing to their different heights and radii it is very easy to excitingly structure relaxation, playground and communication zones with the seating bubbles.

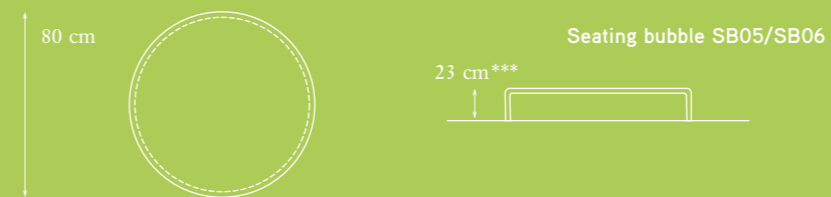
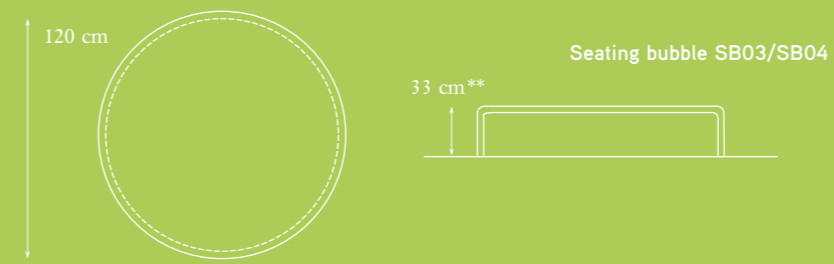
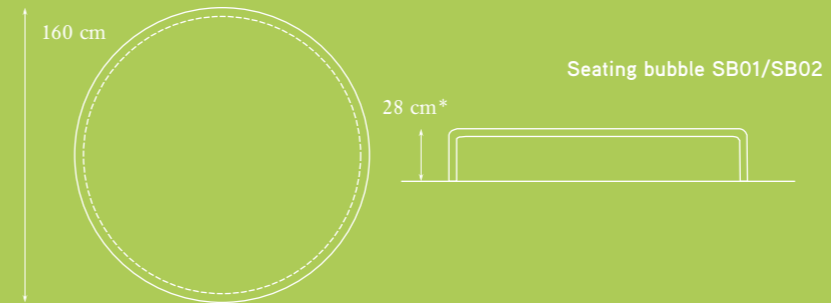

### seating bubble

Seating and playground element of glass fibre concrete. Available in three sizes. Design options with high-class, natural colour pigments that are mixed into the matrix. The glass fibre concrete is not only supplied with a colour but is also imbued.

### Available colours

- Dark-grey
- Anthracite
- Concrete-grey
- Cream-white

\* seating bubble SB02 of a height of 38 cm

\*\* seating bubble SB04 of a height of 43 cm

\*\*\* seating bubble SB06 of a height of 33 cm

### Weight

Seating bubble SB01: 400 kg

Seating bubble SB02: 450 kg

Seating bubble SB03: 300 kg

Seating bubble SB04: 350 kg

Seating bubble SB05: 100 kg

Seating bubble SB06: 150 kg



design Klaus-D. Neumann and Wolf D. Auch

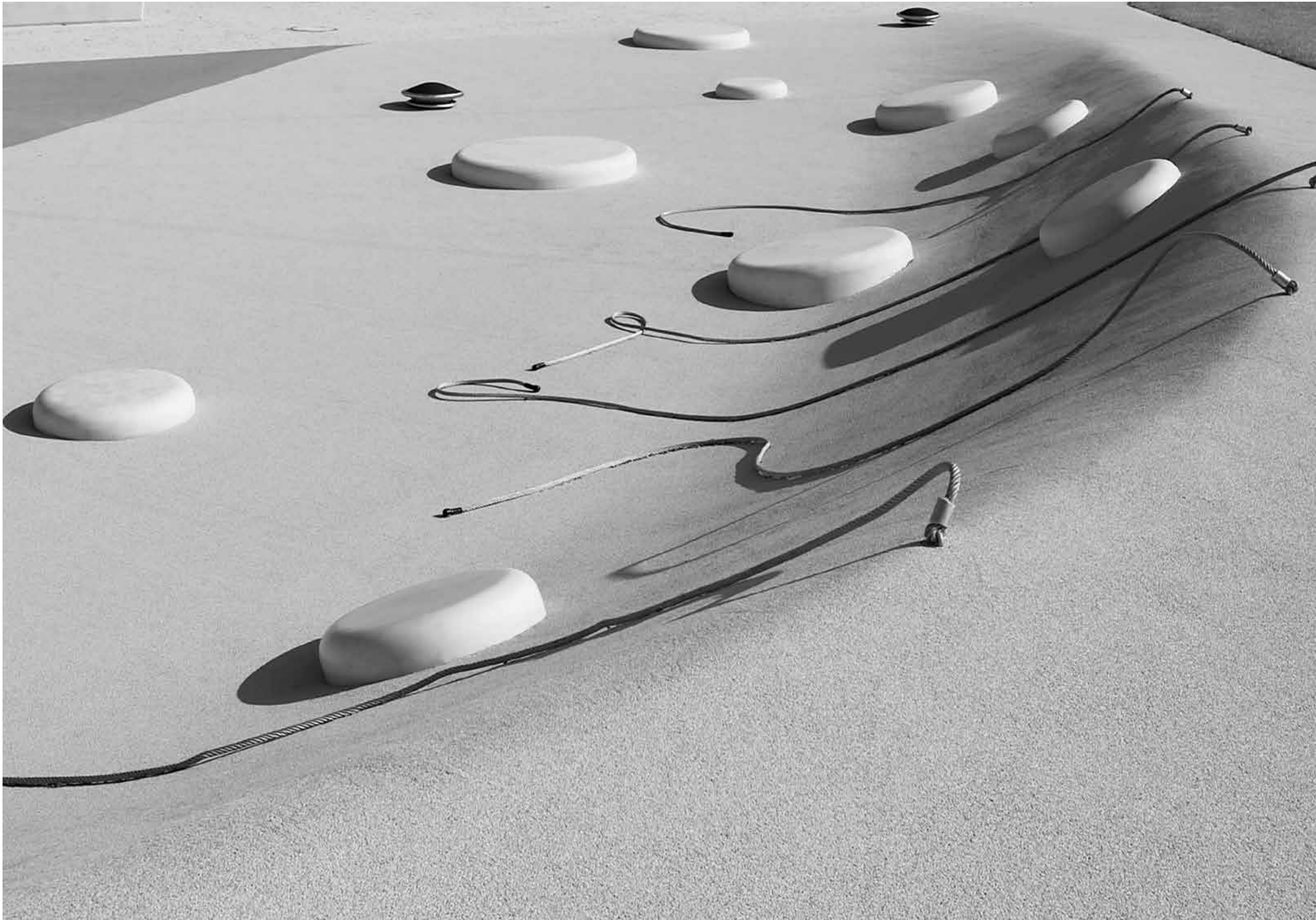



concrete  
urban design

[www.concrete-urban-design.com](http://www.concrete-urban-design.com)  
[info@concrete-urban-design.com](mailto:info@concrete-urban-design.com)

ellhofen/steinbißstraße 15  
88171 weiler-simmerberg, germany

Tel. +49.8384.821090  
Fax +49.8384.821091